



BO GE 1771MW M

60CM MULTIFUNCTION COMBI MICROWAVE OVEN

PRODUCT FEATURES

- 16 Functions
- 13 Automatic Recipes
- Black with Stainless Steel Strip and Mirror Glass
- Sensor Touch Control with Push In Pop Out Knobs
- 5 Shelf Positions with Easy Detachable Side Racks
- Triple Glazed Glass Door
- Delay Start and Automatic Cut Off Timer
- Child Lock
- Cavity volume: 72 litres
- Max. Temperature: 250°C
- Total Power Load: 2.9kW (13 Amp)
- Rated Output (Microwave): 800W
- Accessories: Wire Rack and Baking Tray

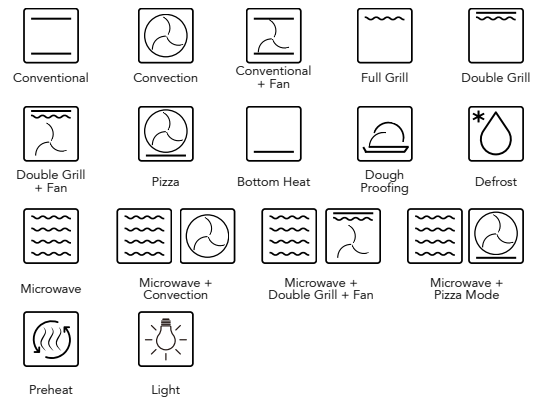

DIMENSIONS

- Product Size: W595 x D566 x H596mm
- Cut-Out Size: W565 x D550 x H585mm

72L LED

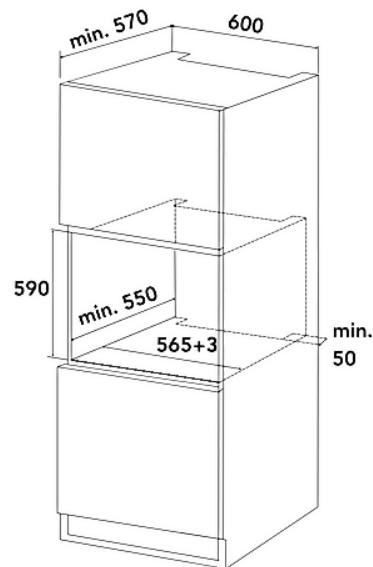
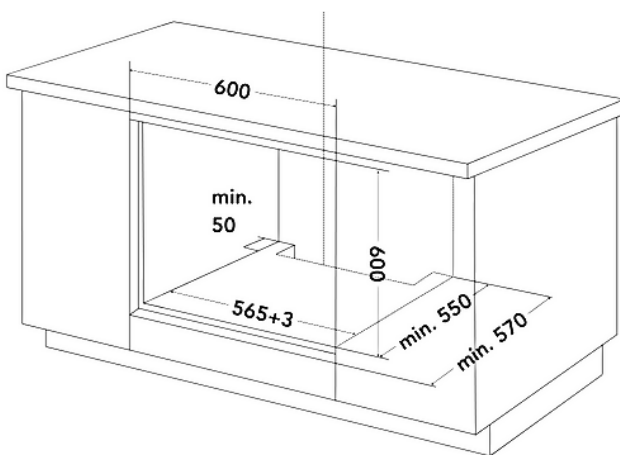

www.ef.com.sg
 EF Home Appliances
 @efappliances

