



EMBRACING FINEST MOMENTS

CK LUNA IS

90CM ISLAND HOOD



PRODUCT FEATURES

- Sensor Touch Control with Gesture Control
- Air Ionizer
- 3 Fan Speeds
- 2-in-1 Charcoal Filter
- 2 x Aluminum Filters
- Stainless Steel with Black Tempered Glass Panel
- Time Delay Function
- LED Light Panel



PERFORMANCES

- Max. Extraction Rate : 1200m³/hr
- Recirculation and Extraction Mode

DIMENSIONS

- W900 x D600 x H660~1160mm

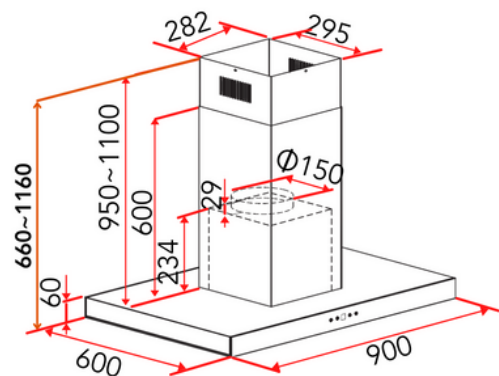

www.ef.com.sg
f EF Home Appliances
@efappliances

