



160891-11

SPACE series, are designed to offer an ideal hot water solution to your home. With its slim horizontal body & unique side pipe connections, the heater can be easily concealed inside the ceiling or install high up in your bathroom; this resulted in great space-saving. Installation is made easy too with our multi-position ring bracket, it allows the heater to hang on the wall or ceiling or sitting on the floor. The heaters are equipped with a high power 3kW stainless steel heating element, the waiting time for hot water will be shortened and insulated by a thick layer of high-density polyurethane foam which guarantees excellent heat retention and lower energy consumption. Available in a few capacities range from 20 to 100 litres.



Stainless Steel Heating Element

Made of SUS 316, perform best even under high temperature and pressure conditions.



Blue Diamond Enamel Tank

Blue diamond coating prolongs the life span of tank.



Overall Polyurethane Foam

Keeps the water warm by minimise heat loss. Save 30% more energy.



Multi-Protections

Inbuilt safety features for Dry-heat protection, Overheat protection and Over pressure protection.



Magnesium Anode

Magnesium anode protect and ensure a longer tank life.



5 Warranty

5 years warranty for heating element.



5 Warranty

5 years warranty for inner tank.

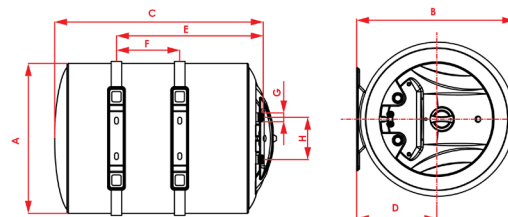

		Product Dimensions							
Capacity (L)		20	30	40	56	50	80	100	
Dimensions (mm)	A	ø355	ø355	ø355	ø355	ø440	ø440	ø440	
	B	375	375	375	375	460	460	460	
	C	397	495	610	840	535	755	905	
	D	190	190	190	190	235	235	235	
	E	258	338	440	625	360	580	730	
	F	70	150	250	400	150	300	450	
	G	G 1/2"	G 1/2"	G 1/2"	G 1/2"	G 1/2"	G 1/2"	G 1/2"	
	H	100	100	100	100	100	100	100	

* Measured in Millimeters (mm)

* Product dimension is for reference only.

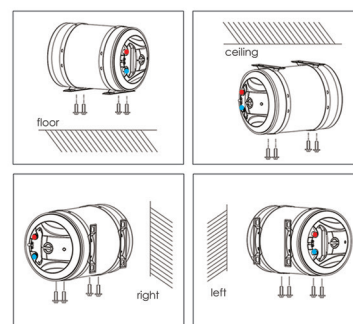

● Hot Water
● Cold Water

Product Information

Model	SPH 20S SIN 3.0 (I)	SPH 30S SIN 3.0 (I)	SPH 40S SIN 3.0 (I)	SPH 56S SIN 3.0 (I)	SPH 50B SIN 3.0(I)	SPH 80B SIN 3.0(I)	SPH 100B SIN 3.0(I)
Capacity	20L	30L	40L	56L	50L	80L	100L
Installation	Horizontally Mount						
Rated Power	3000						
Rated Voltage	230V						
Rated Frequency	50Hz/60Hz						
Heating Time ($\Delta T=30^{\circ}C$)	0h 13min	0h 20min	0h 26min	0h 39min	0h 32min	0h 51min	1h 4min
Max. Working Temperature	75°C						
Max. Working Pressure	0.8Mpa						
Net Weight	8.6kg	11.3kg	13.5kg	18.5kg	15.3kg	21.1kg	26.5kg
Colour	White						
Safety Mark	160891-11	160892-11	160893-11	160890-11	160896-11	160895-11	160894-11
Waterproof IP Rating	IPX4						
Package Included	Water Heater + Pressure Relief Valve + Mounting Hardware						
Warranty (T&C's Apply)	1 Year Parts + Service / 5 Years Heating Element / 5 Years Inner Tank						

*Copyright. All Rights Reserved. Rubine is constantly improving its products and make changes if deemed necessary.